

FICHE D'HOMOLOGATION HOMOLOGATION FORM



COMMISSION INTERNATIONALE DE KARTING – FIA



CARROSSERIE / BODYWORK

Constructeur	<i>Manufacturer</i>	Drew Price Engineering Pty. Ltd.
Marque	<i>Make</i>	Kartech
Modèle	<i>Model</i>	AX9
Catégorie	<i>Category</i>	Toutes / All
Durée de l'homologation	<i>Validity of the homologation</i>	6 ans / years
Nombre de pages	<i>Number of pages</i>	7

La présente Fiche d'Homologation reproduit descriptions, illustrations et dimensions au moment de l'homologation CIK-FIA.

This Homologation Form reproduces descriptions, illustrations and dimensions at the moment of the CIK-FIA homologation.

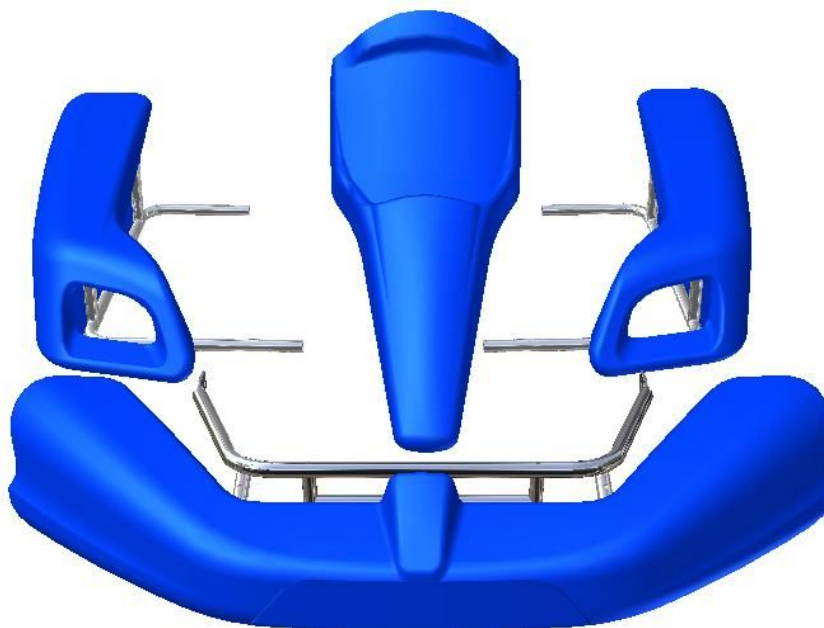
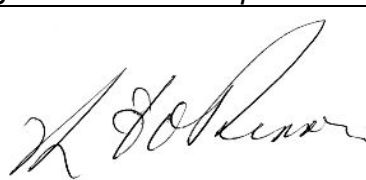



PHOTO VUE DE DESSUS DES ÉLÉMENTS DE CARROSSERIE AVEC LEURS SUPPORTS
PHOTO FROM ABOVE OF BODYWORK ELEMENTS WITH THEIR SUPPORTS

Signature et tampon de l'ASN <i>Signature and stamp of the ASN</i>	Signature et tampon de la CIK-FIA <i>Signature and stamp of the CIK-FIA</i>
 	

CARÉPAGE AVANT AVEC SUPPORTS

Dessin technique (dimensions d'encombrement – diamètre et épaisseur des tubes supports)

FRONT FAIRING WITH SUPPORTS

Technical drawing (fairing main external dimensions – supports diameter and wall thickness)

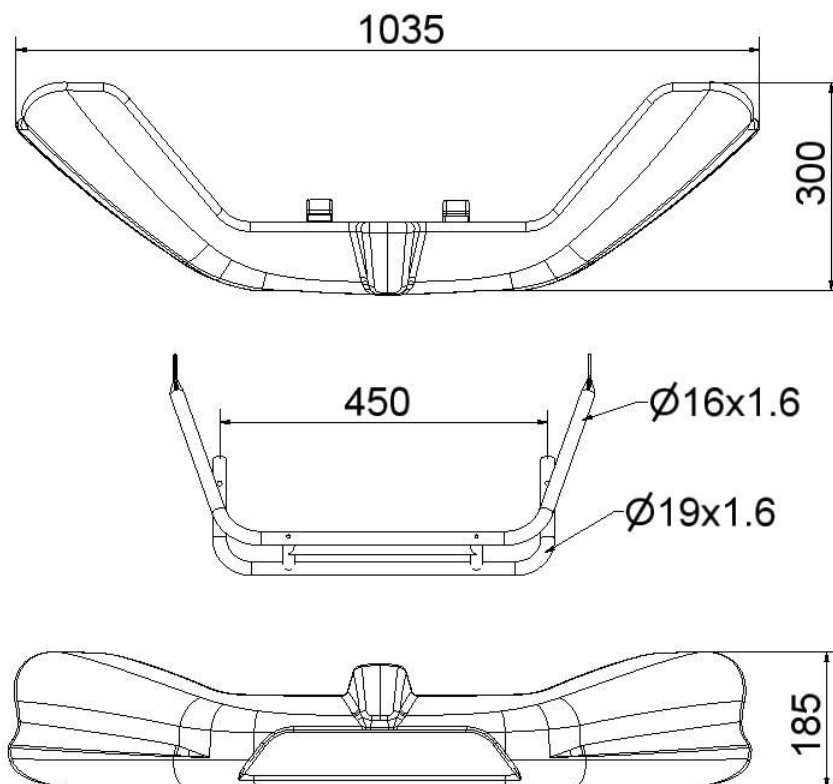
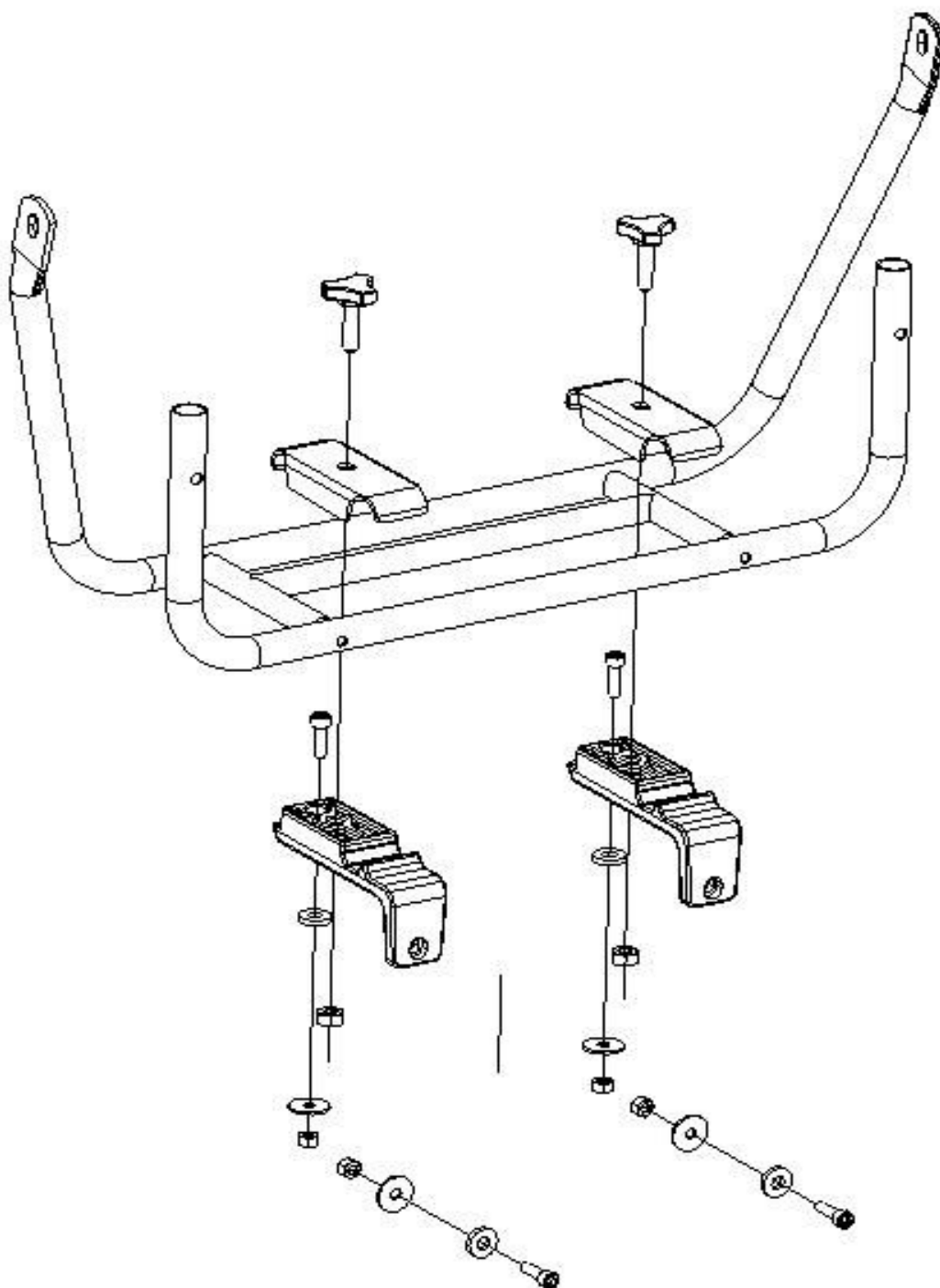

PHOTO (complet avec supports) / (complete with supports)



FIXATION CARÉPAGE FRONTAL
Dessin technique éclaté

FRONT FAIRING ATTACHMENT
Exploded technical drawing



PANNEAU FRONTAL

Dessin technique (dimensions d'encombrement)

FRONT PANEL

Technical drawing (main external dimensions)

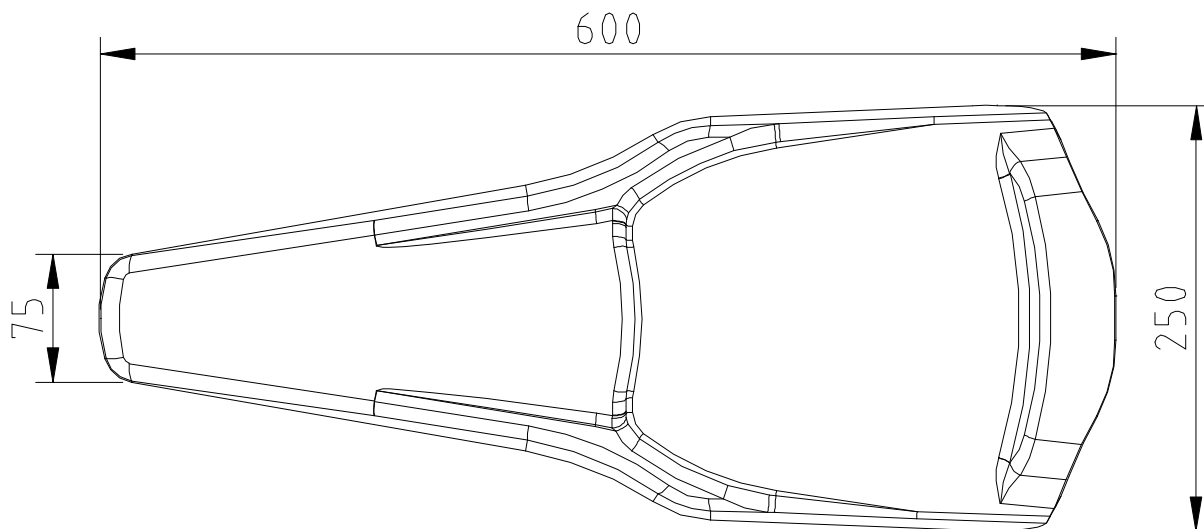

PHOTO



CARROSSERIE LATÉRALE AVEC SUPPORTS

Dessin technique (dimensions d'encombrement – diamètre et épaisseur des tubes supports)

LATERAL BODYWORK WITH SUPPORTS

Technical drawing (bodywork main external dimensions – supports diameter and wall thickness)

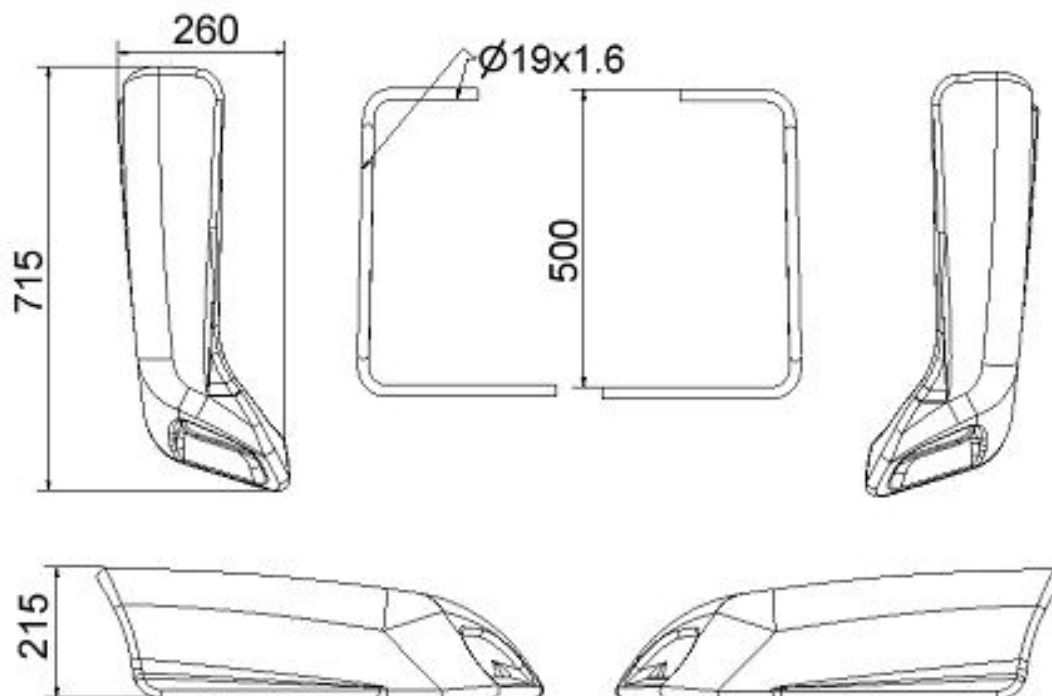

PHOTO AVEC SUPPORT / WITH SUPPORTS



PHOTO DU MARQUAGE DU NUMERO D'HOMOLOGATION
PHOTO OF THE HOMOLOGATION NUMBER MARKING

Le marquage doit rester clairement visible en permanence
The marking must be clearly visible at all times

CARÉNAGE AVANT ET SUPPORTS

FRONT FAIRING AND SUPPORTS

LOWER BAR



UPPER BAR



PANNEAU FRONTAL

FRONT PANEL



CARROSSERIE LATÉRALE ET SUPPORTS

LATERAL BODYWORK AND SUPPORTS

